

Oct. 8, 1946.

J. J. McCANN

2,409,055

METHOD OF MAKING HELMET EAR MUFFS

Filed Feb. 10, 1944

2 Sheets-Sheet 1

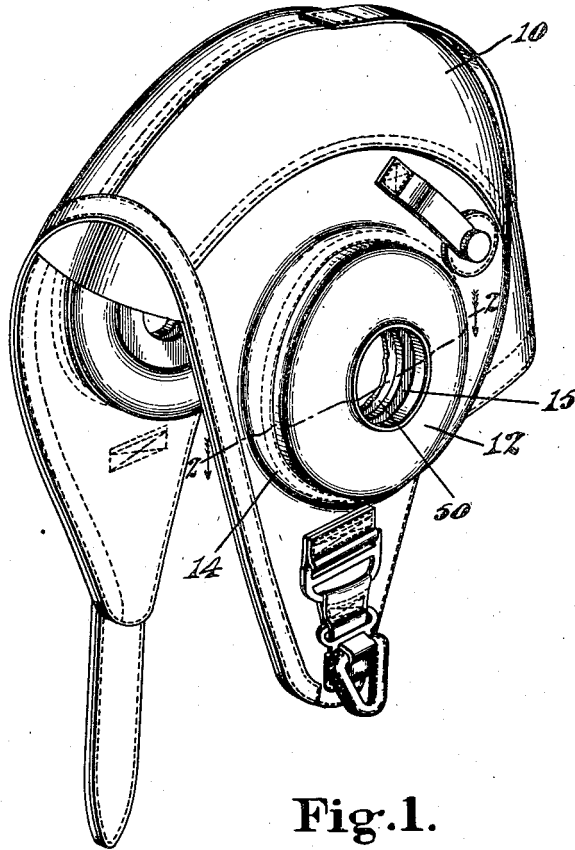

Fig. 1.

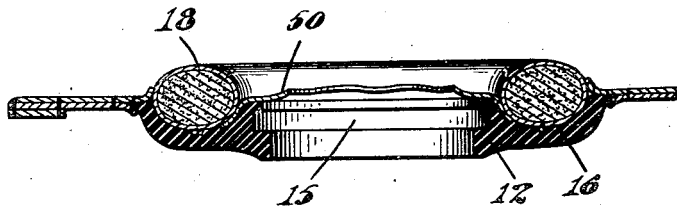

Fig. 2.

INVENTOR.  
JOHN J. McCANN.  
BY Kenway & Withen  
Attorneys

Oct. 8, 1946.

J. J. McCANN

2,409,055

METHOD OF MAKING HELMET EAR MUFFS

Filed Feb. 10, 1944

2 Sheets-Sheet 2

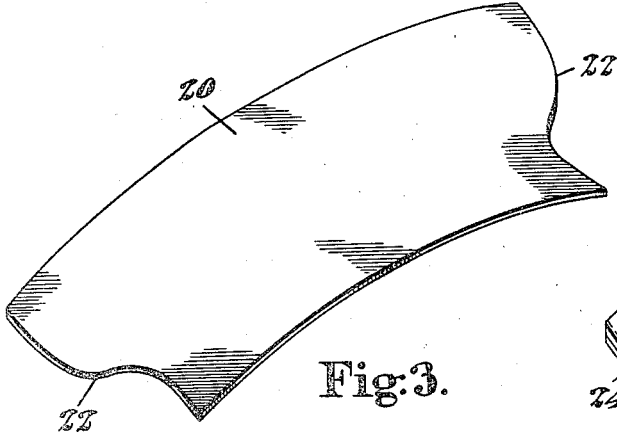

Fig. 3.

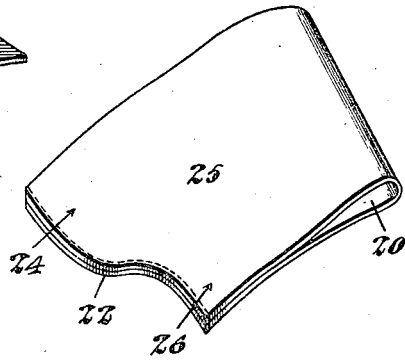

Fig. 4.

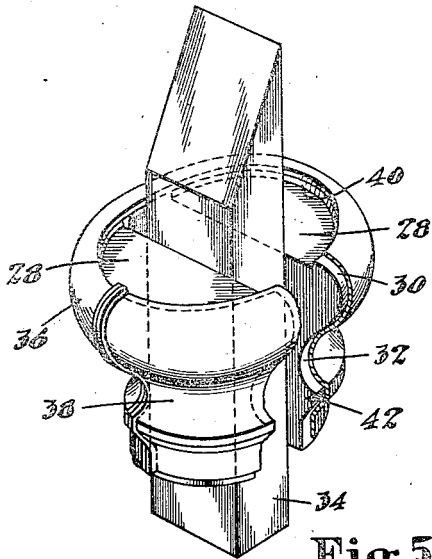

Fig. 5.

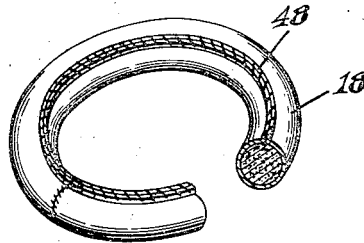

Fig. 7.

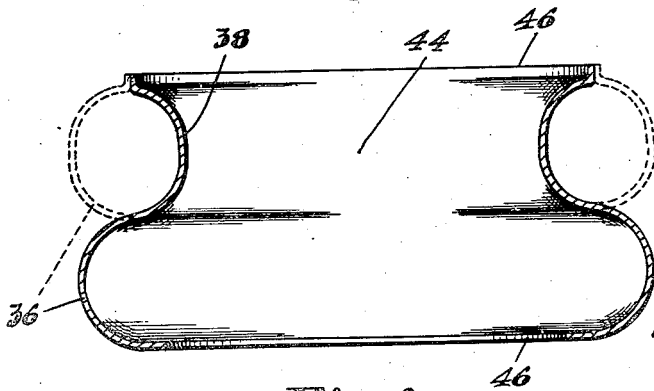

Fig. 6.

INVENTOR.  
JOHN J. McCANN.

BY  
Kenway & Witter  
Attorneys

# UNITED STATES PATENT OFFICE

2,409,055

## METHOD OF MAKING HELMET EAR MUFFS

John J. McCann, Lowell, Mass.

Application February 10, 1944, Serial No. 521,767

11 Claims. (Cl. 2—209)

1

This invention relates especially to a novel method of producing ear muffs of the nature used in aviation helmets. Two of these ear muffs, of annular doughnut-like shape, are mounted in each helmet together with a telephone receiver housed within each muff, the muffs serving the function of insulating the wearer's ears against outside noise and temperature changes. Efficient construction and operation of the helmets require that the muffs shall be of uniform construction and capable of withstanding rough usage without losing their original doughnut shape. The primary object of my invention resides in a novel method of producing a new and improved muff of this nature uniformly, without waste of material, and at an expenditure of time and cost substantially below that heretofore possible.

Each ear muff comprises an annular doughnut-like shell of chamois skin or other suitable material stuffed with kapok or like soft and fluffy product adapted to serve the required functions. In accordance with the preferred form of my invention, I cut a piece of predetermined pattern from a chamois skin and secure the ends together as by stitching or the like to form an annulus. I then superpose this annulus in wet and pliable condition on an expansible form having a substantially annular peripheral surface of S-shaped configuration longitudinally and embodying an outwardly curved convex portion together with an adjacent inwardly curved concave portion of relatively smaller diameter, and expand the mandrel into tight contact with the annulus. When the annulus is dry I remove it from the form, turn the larger portion outside-in to a position forming the outer wall of a hollow ring of which the relatively smaller shaped portion is the inner wall. The annular shell of the ring thus produced is closed by securing the free edges of the inner and outer walls together by stitching or other suitable means. The shell is ordinarily stuffed to the desired degree with kapok or the like prior to this closing of the inner and outer walls. Such novel production of an annular shell and the improved muff of uniform and superior construction resulting therefrom comprises a further object of the invention.

These and other features of the invention will be best understood and appreciated from the following description of a preferred embodiment thereof selected for purposes of illustration and shown in the accompanying drawings, in which,

Fig. 1 is a perspective view of an aviation

2

helmet incorporating two ear muffs of the type comprising my invention,

Fig. 2 is a sectional view taken on line 2—2 of Fig. 1 and showing one of the ear muffs in cross section,

Fig. 3 illustrates a patterned piece of material from which I construct the ear muff,

Fig. 4 illustrates this piece with its ends stitched together and forming the piece into an annulus,

Fig. 5 illustrates the shaping of the annulus over an expansible form,

Fig. 6 is a sectional view longitudinally through the shaped annulus and illustrating in broken lines how a portion thereof is reversed to outside-in position to form the doughnut-like annular shell,

Fig. 7 is a perspective view of the finished muff, illustrated as broken away.

In Fig. 1 is illustrated an aviation helmet 10 formed with two oppositely disposed telephone receiver units each comprising a rubber annulus 12 stitched into the helmet around its periphery 14. Each such rubber annulus has a centrally disposed opening 15 shaped to receive a telephone receiver and an inwardly facing annular depression 16 for receiving one of the ear muffs 18 comprising my invention. The rubber annulus 12 is somewhat elliptical in shape and the ear muff is of like shape within the depression 16.

The ear muff preferably comprises an annular doughnut-like shell of chamois skin stuffed with kapok or like fluffy material. These muffs have heretofore been formed by cutting a somewhat semi-circular shaped piece from a chamois skin and then stitching and simultaneously packing kapok thereinto and expanding the piece to as near the desired shape as possible. This method has provided no definite control over the shape or uniformity of the product and has resulted in a high percentage of rejects that cannot be properly fitted into the helmet.

Excessive amounts of kapok have been used in an effort to give shape to the muff and prevent wrinkles and this has resulted in producing a muff that is relatively hard and uncomfortable. The expanding of the piece to size forms thick and thin areas which affect the diameter and shape of the product, and lack of uniformity in the shape of the muffs has caused considerable difficulty in the fitting of the muffs into the annular depressions 16. My novel method which will now be described eliminates these objections and provides a product in which the individual muffs are so identical in size and shape as to fit

3

perfectly into the annular seats in the helmet and are stuffed to a predetermined degree presenting a soft and comfortable contact to the ears when the helmet is in use.

The outer shell of the muff is preferably made from chamois skin although it may be made from any suitable fabric adaptable to the forming and shaping process now to be described. In accordance with the preferred form of my invention each annular shell is formed from a piece of chamois cut to the patterned shape illustrated in Fig. 3, this piece being oblong and arcuately curved and having end edges 22 of symmetrical outline. The piece is then lapped, as illustrated in Fig. 4, and the edges 22 are stitched together to form the piece into an annulus 25 having one end portion 24 of substantially greater diameter than the other end portion 26.

The next step in the process consists in shaping the annulus on a form to give it the contour illustrated in Figs. 5 and 6. This form is preferably of a laterally expansible nature and I have illustrated it as comprising two half sections 28. The form has one end portion of greater diameter than the other end portion and is of S-shape longitudinally at its periphery, consisting of an outwardly curved convex portion 30 at its larger end and an inward curved concave portion 32 of smaller diameter adjacent thereto. The annulus 25 is first preferably wetted to render it pliable and it is then placed on the form with its larger end located on the larger end of the form as illustrated. The form is then expanded as by forcing the two halves apart by means of a wedge 34. This action stretches the annulus to the desired elliptical shape and conforms it to the peripheral contour of the form, as illustrated in Fig. 6, wherein its portion of greater diameter is outwardly curved at 36 and its adjacent portion of smaller diameter is inwardly curved at 38. The annulus is left thus on the form until it is dry.

The form is provided on its larger end with a shoulder 40 extending uniformly therearound at a predetermined distance inwardly from its periphery and on its smaller end with a sharply defined recess 42 extending uniformly therearound. Before the annulus is removed from the form, after drying, it is trimmed along the shoulder 40 and recess 42 which trimming lines are so located that the annulus as thus trimmed presents the uniformly desired amount of material for forming the final shell.

When it is dry and removed from the form, the annulus presents the appearance illustrated in Fig. 6 wherein the opening at 44 is of the size and shape of the desired opening in the proposed shell and the concavely curved portion 38 provides the inner wall of the shell. The larger convexly curved portion 36 is then turned or reversed to the outside-in position illustrated in broken lines in Fig. 6 in which position it cooperates with the wall 38 and forms the outer wall of the shell. The shell is thereupon stuffed with kapok to a degree giving it a yielding and cushion-like softness and the edges 46 are then stitched together at 48 to close the shell. The muff is adhesively seated with its stitching 48 in the recess 16 and a chamois washer 50 is supported at its periphery between the muff and the bottom of the recess.

It will now be apparent that I have produced a novel method of making doughnut-like shells and ear muffs from relatively soft fabric and that such method not only produces a product in

4

which the individual pieces are uniform in size and shape but furthermore produces the same with a minimum expenditure of material and with an accuracy that permits of no construction errors that might result in an inferior and rejectable product. It will also be apparent that in my finished product the material comprising the shell is neither stretched nor drawn unduly but retains at all times substantially the true and uniform texture and thickness of the original piece from which it is made.

Having thus disclosed my invention what I claim as new and desire to secure by Letters Patent is:

1. A method of forming a fabric piece into predetermined contour, which consists in the steps of shaping said piece in wet condition over a form to S-shape in cross section, removing the piece from the form when dry, and turning one curved portion of said S-shaped piece outside-in to a position wherein it cooperates with the other curved portion thereof to form a chamber enclosed within and between opposed concave walls of said portions.

2. A method of making an annular shell, comprising the steps of shaping an annulus of soft fabric in wet condition over a form to S-shape in cross section longitudinally thereof at its periphery, removing the annulus from the form when dry, and turning one curved portion of the S-shaped annulus outside-in to a position wherein it cooperates with the other curved portion thereof to form an annular shell.

3. A method of making an annular shell, comprising the steps of placing an annulus of soft fabric over an expansible form having a substantially annular and convex outwardly curved peripheral portion and an adjacent substantially annular and concave inwardly curved peripheral portion of relatively smaller diameter, expanding the form to bring said portions into tight shaping contact with the annulus, removing the shaped annulus from the form, turning the larger portion outside-in to a position forming the outer wall of a hollow ring of which the relatively smaller shaped portion is the inner wall, and securing the free edges of the inner and outer walls together.

4. A method of making an annular shell, comprising the steps of forming an annulus by securing together as by stitching or the like the ends of an oblong sheet of soft fabric, placing the annulus over and shaping it to a form having a substantially annular outwardly curved convex portion and an adjacent substantially annular inwardly curved concave portion of relatively smaller diameter, removing the shaped annulus from the form, turning the larger portion outside-in to a position forming the outer wall of a hollow ring of which the relatively smaller shaped portion is the inner wall, and securing the free edges of the inner and outer walls together.

5. A method of making an annular shell, comprising the steps of cutting from a sheet of soft fabric an arcuately curved segmental piece having its two end edges of like pattern, securing said edges together to form the piece into an annulus having one end portion of greater diameter than the other end portion, placing the annulus over and shaping it to a form in which said greater diameter portion engages a substantially annular outwardly curved convex portion of the form and said other end portion engages an adjacent substantially annular inwardly curved concave portion of the form of relatively smaller diameter,

5

removing the shaped annulus from the form, turning the larger portion outside-in to a position forming the outer wall of a hollow ring of which the relatively smaller portion is the inner wall, and securing the two edges of the inner and outer walls together.

6. A method of making an annular shell, comprising the steps of forming an annulus by securing together as by stitching or the like the ends of an oblong sheet of soft fabric, placing the annulus over and shaping it to a split form embodying a plurality of segmental sections having like peripheries of S-shape in cross section longitudinally thereof and all cooperating to provide the form with an outwardly curved convex portion and an adjacent inwardly curved concave portion of relatively smaller diameter, spreading the sections radially apart to stretch the annulus and shape it to said peripheries, removing the shaped annulus from the form, turning the larger portion outside-in to a position forming the outer wall of a hollow ring of which the relatively smaller shaped portion is the inner wall, and securing the free edges of the inner and outer walls together.

7. A method of making an annular shell of elliptical shape, comprising the steps of forming an annulus by securing together as by stitching or the like the ends of an oblong sheet of soft fabric, placing the annulus over and shaping it to a split form embodying two cooperating half sections having like S-shaped peripheral contours in cross section longitudinally thereof each comprising an outwardly curved convex portion and an adjacent and relatively smaller inwardly curved concave portion, spreading the two sections apart to stretch the annulus into an ellipse and shape it to said contours, removing the shaped annulus from the form, turning the larger portion outside-in to a position forming the outer wall of a hollow ring of which the relatively smaller shaped portion is the inner wall, and securing the free edges of the inner and outer walls together.

8. A method of making an annular shell, comprising the steps of forming an annulus by securing together the free end edge portions of an oblong sheet of soft fabric, placing the annulus over and shaping it to a form having a substantially annular outwardly curved convex portion and an adjacent substantially annular inwardly curved concave portion of relatively smaller diameter, trimming the free edges of the annulus to predetermined lines on the form, removing the shaped annulus from the form, turning the larger portion outside-in to a position forming

6

the outer wall of a hollow ring of which the relatively smaller shaped portion is the inner wall, and securing the trimmed edges of the inner and outer walls together.

9. A method of making ear muffs or the like of stuffed annular construction, comprising the steps of placing an annulus of soft fabric over and shaping it to a form having a substantially annular outwardly curved convex portion and an adjacent substantially annular inwardly curved concave portion of relatively smaller diameter, removing the shaped annulus from the form, turning the larger portion outside-in to a position forming the outer wall of a hollow ring of which the relatively smaller shaped portion is the inner wall, stuffing the ring with a suitable material, and stitching the free edges of the inner and outer walls together.

10. A method of making ear muffs or the like of stuffed annular construction, comprising the steps of forming an annulus by securing together as by stitching or the like the ends of an oblong sheet of flexible leather or the like, wetting the annulus and shaping it tightly over a form having a substantially annular outwardly curved convex portion and an adjacent substantially annular inwardly curved concave portion of relatively smaller diameter, drying the annulus and then removing it from the form, turning the larger portion outside-in to a position forming the outer wall of a hollow ring of which the relatively smaller shaped portion is the inner wall, stuffing the ring with a suitable material, and securing the free edges of the inner and outer walls together as by stitching or the like.

11. A method of making an elliptical ear muff or the like of stuffed annular construction, comprising the steps of forming an annulus by securing together as by stitching or the like the ends of an oblong sheet of soft fabric, placing the annulus over an expansible form having a peripheral contour of S-shape in cross section longitudinally thereof and comprising an outwardly curved convex portion and an adjacent and relatively smaller inwardly curved concave portion, expanding the form laterally in two opposite directions to spread the annulus to elliptical shape and shape it to said contour, removing the shaped annulus from the form, turning the larger portion outside-in to a position forming the outer wall of a hollow ring of which the relatively smaller shaped portion is the inner wall, stuffing the ring with a suitable material, and securing the free edges of the inner and outer walls together.

JOHN J. McCANN.